

Strainer

BOA-S

Type Series Booklet



Legal information/Copyright

Type Series Booklet BOA-S

All rights reserved. The contents provided herein must neither be distributed, copied, reproduced, edited or processed for any other purpose, nor otherwise transmitted, published or made available to a third party without the manufacturer's express written consent.

Subject to technical modification without prior notice.

© KSB SE & Co. KGaA, Frankenthal 30/07/2019

Contents

Check Valves and Strainers 4

 Strainers to DIN/EN..... 4

 BOA-S..... 4

 Main applications..... 4

 Fluids handled 4

 Operating data..... 4

 Valve body materials..... 4

 Design details 4

 Product benefits..... 4

 Product information 5

 Certifications 5

 Related documents 5

 Purchase order specifications 5

 Pressure/temperature ratings..... 5

 Materials..... 6

 Dimensions and weights..... 7

 Installation instructions 10

 Chemical resistance chart 11

Check Valves and Strainers

Strainers to DIN/EN

BOA-S



Main applications

- Hot-water heating systems
- Air-conditioning systems
- Process engineering
- Chemical industry
- Petrochemical industry
- Sugar industry
- Heat recovery systems
- Boiler feed applications
- Boiler recirculation
- Pulp and paper industry

Fluids handled

- High-temperature hot water
- Saturated steam
- Thermal oil
- Liquids and gases not chemically or mechanically aggressive to the valve materials.
- Other fluids on request.

Operating data

Operating properties

Characteristic	Value	
	EN-GJL-250	EN-GJS-400-18-LT
Nominal pressure	PN 6/16	PN 16/25
Nominal size	DN 15 - 400	DN 15 - 300
Max. permissible pressure [bar]	16	25
Min. permissible temperature [°C]	≥ -10	≥ -10
Max. permissible temperature [°C]	≤ +300	≤ +350

Selection as per pressure/temperature ratings (⇒ Page 5)

Valve body materials

Overview of available materials

Material	Material number	Temperature limit
EN-GJL-250	5.1301	≤ 300 °C
EN-GJS-400-18-LT	5.3103	≤ 350 °C

Design details

Design

- Y-pattern strainer
- Screen made of stainless steel
- Screen accurately guided in cover and body
- Outside confined cover gasket
- Drain plug
- Size DN 150 and above: additional screen cage made of perforated stainless steel sheet
- Flanges to DIN EN 1092-2 Type 21
- Exterior coating: blue, RAL 5002

Variants

- Fine screen
- High temperature resistant paint, aluminium grey (EN-GJS-400-18-LT only)
- Other flange designs (EN-GJS-400-18-LT only)
- Certification to customer specification

Product benefits

- Long service life due to screen made of stainless steel.
- Time and cost saving replacement of screen without removing the body insulation by using the studs as centering aids.
- Standard drain plug for easy inspection and drainage of strainer, particularly of strainers with a large nominal size.

Product information
Product information as per Regulation No. 1907/2006 (REACH)

For information as per chemicals Regulation (EC) No. 1907/2006 (REACH), see <http://www.ksb.com/reach>.

Product information as per Directive 2014/34/EU (ATEX)

The valves do not have a potential internal source of ignition and can be used in potentially explosive atmospheres, Group II, category 2 (zones 1+21) and category 3 (zones 2+22) to ATEX 2014/34/EU.

Product information as per Pressure Equipment Directive 2014/68/EU (PED)

The valves satisfy the safety requirements of Annex I of the European Pressure Equipment Directive 2014/68/EU (PED) for fluids in Groups 1 and 2.

Certifications

Overview

Label	Effective in:	Comment
	Worldwide	Approved for marine applications
	Worldwide	Approved for marine applications

Related documents

Information/documents

Document	Reference number
Operating manual	0570.8
Typical tender for BOA-S JL	7125.521
Typical tender for BOA-S JS	7125.522

Purchase order specifications

Please specify the following information in all enquiries or purchase orders:

1. Type
2. Nominal pressure
3. Nominal size
4. Material
5. Variants
6. Reference number

Pressure/temperature ratings

Test pressure and operating pressure

PN	Material	Shell and leak test	Permissible operating pressure [bar] ¹⁾²⁾							
		With water	[°C]							
		Tests P10 and P11 to DIN EN 12266-1								
		[bar]	-10 to +120	150	180	200	230	250	300	350
6	EN-GJL-250	9	6	5,4	5	4,8	4,4	4,2	3,6	-
16		24	16	14,4	13,4	12,8	11,8	11,2	9,6	-
16	EN-GJS-400-18-LT	24	16	15,5	-	14,7	-	13,9	12,8	11,2
25		37,5	25	24,3	-	23	-	21,8	20	17,5

1) Intermediate temperatures can be derived by linear interpolation.
 2) Static load

Materials

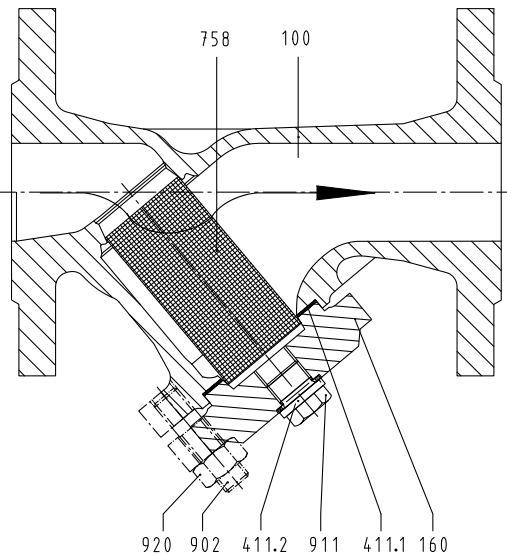

Fig. 1: BOA-S

Parts list

Part No.	Description	PN	Material	Note
100	Body	6, 16	EN-GJL-250 (5.1301)	-
		16, 25	EN-GJS-400-18-LT (5.3103)	-
160 ³⁾	Cover	6,16	EN-GJL-250 (5.1301)	-
		16, 25	EN-GJS-400-18-LT (5.3103)	-
411.1 ⁴⁾	Joint ring	6, 16	CrNi steel/graphite	-
		16, 25	CrNi steel/graphite	-
411.2	Joint ring	6, 16, 25	A4	-
758 ⁴⁾	Screen	6, 16	X 6 CrNiTi 18 10 (1.4541)	-
		16, 25	X 5 CrNi 18 10 (1.4301)	-
191	Screen cage	6, 16	X 6 CrNiTi 18 10 (1.4541)	≥ DN 150
		16, 25	X 5 CrNi 18 10 (1.4301)	≥ DN 150
902	Stud	6, 16	5.6 or 8.8	gal ZN
		16, 25	C 35 E	gal ZN
911	Drain plug	6, 16	A4 or A2	-
		16, 25	C 35 E	gal ZN
920	Hexagon nut	6, 16	5-2 or 8	gal ZN
		16, 25	C 35 E	gal ZN

3) Spare part (complete with screw plug)
4) Spare part

Dimensions and weights

Dimensions and weights of EN-GJL-250 (5.1301) variant

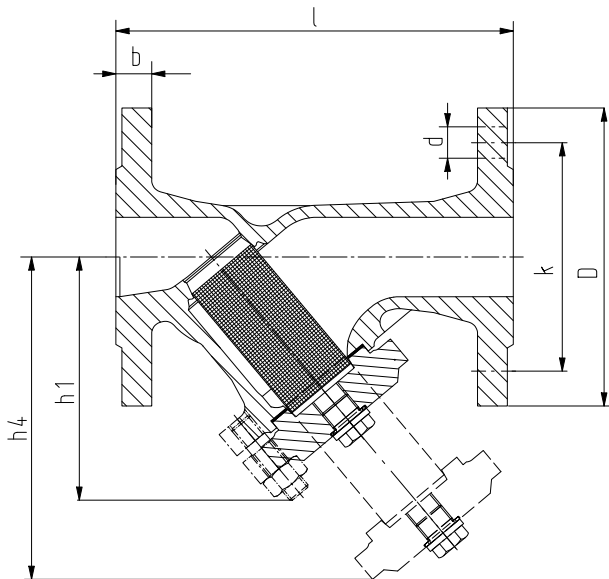

Fig. 2: BOA-S

Dimensions and weights

PN	DN	b	D	h ₁	h ₄	k	l	n × d	Drain plug	[kg]
		[mm]	[mm]	[mm]	[mm]	[mm]	[mm]	[mm]	[inch]	
6	15	12	80	90	135	55	130	4 × 11	G 3/8	2,5
	20	14	90	100	160	65	150	4 × 11	G 3/8	3
	25	14	100	115	180	75	160	4 × 11	G 3/8	4,5
	32	16	120	135	215	90	180	4 × 14	G 3/8	5,5
	40	16	130	150	240	100	200	4 × 14	G 3/8	7
	50	16	140	160	250	110	230	4 × 14	G 3/8	9
	65	16	160	180	285	130	290	4 × 14	G 1/2	13
	80	18	190	215	330	150	310	4 × 18	G 1/2	19
	100	18	210	240	395	170	350	4 × 18	G 1/2	26
	125	20	240	280	455	200	400	8 × 18	G 1/2	38
	150	20	265	330	525	225	480	8 × 18	G 1/2	54
200	22	320	405	650	280	600	8 × 18	G 1/2	110	
16	15	14	95	90	135	65	130	4 × 14	G 3/8	3
	20	16	105	100	160	75	150	4 × 14	G 3/8	4
	25	16	115	115	180	85	160	4 × 14	G 3/8	5
	32	18	140	135	215	100	180	4 × 18	G 3/8	7
	40	18	150	150	240	110	200	4 × 18	G 3/8	9
	50	20	165	160	250	125	230	4 × 18	G 3/8	12
	65	20	185	180	285	145	290	4 × 18	G 1/2	16
	80	22	200	215	330	160	310	8 × 18	G 1/2	21
	100	24	220	240	395	180	350	8 × 18	G 1/2	30
	125	26	250	280	455	210	400	8 × 18	G 1/2	43
	150	26	285	330	525	240	480	8 × 22	G 1/2	61
	200	30	340	405	650	295	600	12 × 22	G 1/2	121
	250	32	405	540	870	355	730	12 × 26	G 1/2	154
	300	32	460	680	1110	410	850	12 × 26	G 1/2	255
350	36	520	755	1200	470	980	16 × 28	G 1 1/2	373	
400	38	580	835	1320	525	1100	16 × 31	G 1 1/2	540	

Dimensions [mm]

PN	DN	Standard screen				Fine screen			
		Kv [m ³ /h]	Zeta value	Mesh width	Wire diameter	Kv [m ³ /h]	Zeta value	Mesh width	Wire diameter
6	15	5,7	2,5	1,0	0,5	5,3	2,9	0,25	0,16

7125.1/22-EN

PN	DN	Standard screen				Fine screen			
		Kv [m ³ /h]	Zeta value	Mesh width	Wire diameter	Kv [m ³ /h]	Zeta value	Mesh width	Wire diameter
6	20	10,4	2,4	1,0	0,5	9,5	2,8	0,25	0,16
	25	16,4	2,3	1,0	0,5	15,1	2,7	0,25	0,16
	32	27,3	2,3	1,0	0,5	24,7	2,7	0,25	0,16
	40	42	2,3	1,0	0,5	38,2	2,8	0,25	0,16
	50	64,7	2,4	1,0	0,5	57,2	3,0	0,25	0,16
	65	96	3,1	1,25	0,63	81,1	4,3	0,25	0,16
	80	149	3,0	1,25	0,63	119	4,6	0,25	0,16
	100	223	3,2	1,6	1,0	181	4,9	0,25	0,16
	125	347	3,2	1,6	1,0	281	5,0	0,25	0,16
	150	480	3,5	1,6	1,0	380	5,6	0,25	0,16
	200	853	3,5	1,6	1,0	672	5,7	0,25	0,16
16	15	5,7	2,5	1,0	0,5	5,3	2,9	0,25	0,16
	20	10,4	2,4	1,0	0,5	9,5	2,8	0,25	0,16
	25	16,4	2,3	1,0	0,5	15,1	2,7	0,25	0,16
	32	27,3	2,3	1,0	0,5	24,7	2,7	0,25	0,16
	40	42	2,3	1,0	0,5	38,2	2,8	0,25	0,16
	50	64,7	2,4	1,0	0,5	57,2	3,0	0,25	0,16
	65	96	3,1	1,25	0,63	81,1	4,3	0,25	0,16
	80	149	3,0	1,25	0,63	119	4,6	0,25	0,16
	100	223	3,2	1,6	1,0	181	4,9	0,25	0,16
	125	347	3,2	1,6	1,0	281	5,0	0,25	0,16
	150	480	3,5	1,6	1,0	380	5,6	0,25	0,16
	200	853	3,5	1,6	1,0	672	5,7	0,25	0,16
	250	1104	5,1	1,6	1,0	838	8,9	0,25	0,16
	300	1450	6,1	1,6	1,0	1090	10,9	0,25	0,16
	350	1800	7,4	1,6	1,0	1339	13,1	0,25	0,16
400	2200	8,4	1,6	1,0	1640	14,9	0,25	0,16	

Mating dimensions as per standard

Face-to-face lengths: DIN EN 558/1, ISO 5752/1
 Flanges: DIN EN 1092-2, flange type 21
 Flange facing: DIN EN 1092-2, type B

Dimensions and weights of EN-GJS-400-18-LT (5.3103) variant

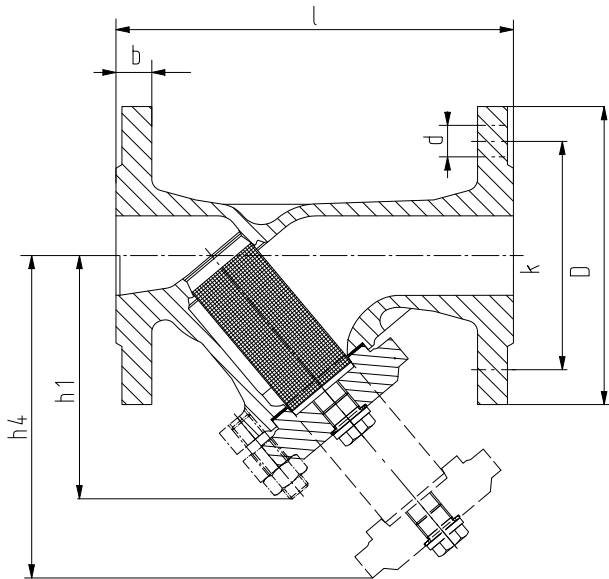

Fig. 3: BOA-S

Dimensions [mm] and weights [kg]

PN	DN	l	D	k	n x d	b	h ₁	h ₄	Drain plug	[kg]
		[mm]	[mm]	[mm]	[mm]	[mm]	[mm]	[mm]	[inch]	
16	15	130	95	65	4 x 14	16	75	115	G 1/2	3,5
	20	150	105	75	4 x 14	18	75	115	G 1/2	4
	25	160	115	85	4 x 14	18	90	135	G 1/2	5,5
	32	180	140	100	4 x 18	20	90	135	G 1/2	7
	40	200	150	110	4 x 18	20	110	170	G 1/2	9
	50	230	165	125	4 x 18	22	120	190	G 1/2	12
	65	290	185	145	4 x 18	24	140	220	G 1/2	16
	80	310	200	160	8 x 18	26	165	265	G 1	21
	100	350	220	180	8 x 18	28	220	340	G 1	28
	125	400	250	210	8 x 18	30	260	410	G 1	41
	150	480	285	240	8 x 22	30	300	475	G 1	58
	200	600	340	295	12 x 22	34	360	580	G 1	121
25	250	730	405	355	12 x 26	36	470	680	G 1	154
	300	850	460	410	12 x 26	36	560	820	G 1	255
	15	130	95	65	4 x 14	16	75	115	G 1/2	3,5
	20	150	105	75	4 x 14	18	75	115	G 1/2	4
	25	160	115	85	4 x 14	18	90	135	G 1/2	5,5
	32	180	140	100	4 x 18	20	90	135	G 1/2	7
	40	200	150	110	4 x 18	20	110	170	G 1/2	9
	50	230	165	125	4 x 18	22	120	190	G 1/2	12
	65	290	185	145	8 x 18	24	140	220	G 1/2	16
	80	310	200	160	8 x 18	26	165	265	G 1	21
	100	350	235	190	8 x 22	28	220	340	G 1	32
	125	400	270	220	8 x 26	30	260	410	G 1	47
150	480	300	250	8 x 26	34	300	475	G 1	64	
200	600	360	310	12 x 26	34	360	580	G 1	133	

Dimensions [mm]

PN	DN	Standard screen				Fine screen			
		Kv [m ³ /h]	Zeta value	Mesh width	Wire diameter	Kv [m ³ /h]	Zeta value	Mesh width	Wire diameter
16	15	6,3	2,1	1,25	0,71	5,0	3,2	0,25	0,17
	20	11,3	2,0	1,25	0,71	9,0	3,2	0,25	0,17
	25	18,5	1,8	1,25	0,71	14,8	2,9	0,25	0,17
	32	22,5	3,3	1,25	0,71	18,0	5,2	0,25	0,17
	40	37,5	2,9	1,25	0,71	30,0	4,6	0,25	0,17

PN	DN	Standard screen				Fine screen			
		Kv [m ³ /h]	Zeta value	Mesh width	Wire diameter	Kv [m ³ /h]	Zeta value	Mesh width	Wire diameter
16	50	60,0	2,8	1,25	0,71	48,0	4,4	0,25	0,17
	65	110,5	2,3	2,0	0,50	85,0	4,0	0,25	0,17
	80	170,3	2,3	2,0	0,50	131,0	3,8	0,25	0,17
	100	245,7	2,7	2,0	0,50	189,0	4,5	0,25	0,17
	125	416,0	2,3	2,0	0,50	320,0	3,8	0,25	0,17
	150	608,4	2,2	2,0	0,50	494,0	3,3	0,25	0,17
	200	999,7	2,6	2,0	0,50	818,0	3,8	0,25	0,17
	250	1440,4	3,0	2,0	0,50	1184,0	4,5	0,25	0,17
	300	1976,0	3,3	2,0	0,50	1631,0	4,9	0,25	0,17
25	15	6,3	2,1	1,25	0,71	5,0	3,2	0,25	0,17
	20	11,3	2,0	1,25	0,71	9,0	3,2	0,25	0,17
	25	18,5	1,8	1,25	0,71	14,8	2,9	0,25	0,17
	32	22,5	3,3	1,25	0,71	18,0	5,2	0,25	0,17
	40	37,5	2,9	1,25	0,71	30,0	4,6	0,25	0,17
	50	60,0	2,8	1,25	0,71	48,0	4,4	0,25	0,17
	65	110,5	2,3	2,0	0,50	85,0	4,0	0,25	0,17
	80	170,3	2,3	2,0	0,50	131,0	3,8	0,25	0,17
	100	245,7	2,7	2,0	0,50	189,0	4,5	0,25	0,17
	125	416,0	2,3	2,0	0,50	320,0	3,8	0,25	0,17
	150	608,4	2,2	2,0	0,50	494,0	3,3	0,25	0,17
	200	999,7	2,6	2,0	0,50	818,0	3,8	0,25	0,17

Mating dimensions as per standard

Face-to-face lengths: DIN EN 558/1, ISO 5752/1
 Flanges: DIN EN 1092-2, flange type 21-2
 Flange facing: DIN EN 1092-2, type B

Installation instructions

- i** The flow direction must correspond to the arrow indicated on the valve body.
- i** In both horizontal and vertical pipes, installing the strainer with the screen hanging downwards is recommended to facilitate cleaning.

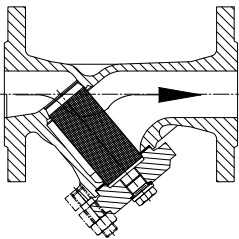

Horizontal installation

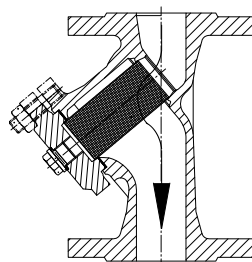

Vertical installation

Chemical resistance chart

The information provided in this chemical resistance chart is based on experience, the Dechema lists as well as manufacturer information. Corrosion resistance is largely dependent on the operating conditions, temperatures and concentrations. Hydroabrasive wear in fluids containing solids is not covered in this list. All information provided herein, therefore, only serves as an orientation. Warranty claims may not be asserted on the basis of this list!

Symbols key

Symbol	Description
✓	The fluid handled is not normally aggressive toward the materials.
✗	The fluid handled is aggressive toward the materials. Valve cannot be used.
○	The material or valve can only be used under certain operating conditions. Please enquire accordingly, stating the operating conditions such as concentration, temperature, pH and composition of the fluid handled.

Chemical resistance chart for water⁵⁾

Fluids handled	A ⁶⁾	B ⁷⁾
Brackish water ⁸⁾	✗	✗
Service water ⁸⁾	✓	✓
Fire-fighting water	✓	✓
Chlorinated water (≤ 0.6 mg/kg)	✓	✓
Deionised water (demineralised water) ⁹⁾	○	○
Distilled water ⁹⁾	○	○
Boiler feed water	✓	✓
Hot water	✓	✓
High-temperature hot water	✓	✓
Condensate	✓	✓
Oil-free cooling water	✓	✓
Oil-containing cooling water	✓	✓
Ozonised water (≤ 0.5 mg/kg)	✓	✓
Pure water	✓	✓
Seawater	✗	✗
Scale-forming water ⁸⁾	○	○
Raw water ⁸⁾	✓	✓
Partly desalinated water ⁹⁾	○	○
Fully desalinated water ⁹⁾	○	○
Municipal waste water ⁸⁾¹⁰⁾	✓	✓
Industrial waste water ⁸⁾¹¹⁾	✓	✓

Chemical resistance chart for oils (aromatic content 5 mg/kg)

Fluids handled	A ⁶⁾	B ⁷⁾
Vegetable oils	✓	✓
Mineral oils	✓	✓
Synthetic oils	✓	✓
Crude oil	✓	✓
Petroleum	✓	✓

Fluids handled	A ⁶⁾	B ⁷⁾
Light fuel oil	✓	✓
Linseed oil	✓	✓
Oil/water emulsion ⁸⁾	✓	✓
Jet fuel	○ ¹²⁾	✓
Petrol	○ ¹²⁾	✓
Kerosene	○ ¹²⁾	✓

Chemical resistance chart for refrigerants

Fluids handled	A ⁶⁾	B ⁷⁾
Ammonium hydroxide (≤ 30 %, ≤ 25 °C)	✓	✓
Glycol (ethylene glycol)	✓	✓
Propylene glycol	✓	✓
Water/glycol mixture (20 % ≤ c ≤ 50 %, ≤ 90 °C)	✓	✓
Inorganic cooling brine, pH 7.5	✓	✓

Chemical resistance chart for thermal oils

Fluids handled	A ⁶⁾	B ⁷⁾
Synthetic thermal oils	✓	✓
Mineral-based thermal oils	✓	✓

Chemical resistance chart for acids

Fluids handled	A ⁶⁾	B ⁷⁾
Hydrochloric acid	✗	✗
Sulphuric acid (pure, technical, concentrated)	✗	✗
Sulphurous acid	✗	✗
Fatty acid	✗	✗
Nitric acid	✗	✗

Chemical resistance chart for cleaning agents

Fluids handled	A ⁶⁾	B ⁷⁾
Lye for bottle rinsers (e.g. P3) ≤ 80 °C ⁸⁾	○	○
Lye for metal cleaning ≤ 80 °C ⁸⁾	○	○

Chemical resistance chart for steam

Fluids handled	A ⁶⁾	B ⁷⁾
Saturated steam	○ ¹²⁾	✓

Chemical resistance chart for other fluids

Fluids handled	A ⁶⁾	B ⁷⁾
Sodium hydroxide (≤ 50 %, ≤ 50 °C)	○	○
Natural gas	✓	✓
Oil-containing compressed air	✓	✓
Dry chlorine (≤ 30 °C)	○	✓
Ammonia	✓	✓
Butane (liquefied gas)	✓	✓
Aqueous glycerine	✓	✓
Carbon dioxide (gas)	✓	✓
Carbon dioxide (aqueous solution)	✗	✗

- 5) General criteria for water to be handled by products made of non-alloyed materials: pH > 7; chlorides (Cl⁻) < 150 mg/kg; chlorine (Cl) < 0.6 mg/kg. Other factors to be considered: hardness, carbon dioxide content (CO₂), oxygen (O₂) and dissolved substances. Contact KSB if limits are exceeded!
- 6) EN-GJL-250, Tmax. +300 °C
- 7) EN-GJS-400-18-LT, Tmax. +350 °C
- 8) Without solids
- 9) Can only be used for installations and the respective water quality as specified in the VdTÜV 1466 or VDI 2035 guidelines. A pH ≥ 9.5 and an oxygen content of ≤ 0.02 mg/l are also recommended.
- 10) Biologically treated
- 11) Non-corrosive, non-abrasive
- 12) EN-GJS-400-18-LT is recommended for safety reasons (ductility).



KSB SE & Co. KGaA
Johann-Klein-Straße 9 • 67227 Frankenthal (Germany)
Tel. +49 6233 86-0
www.ksb.com