

Lift Check Valve

**BOA-RVK**

**Type Series Booklet**

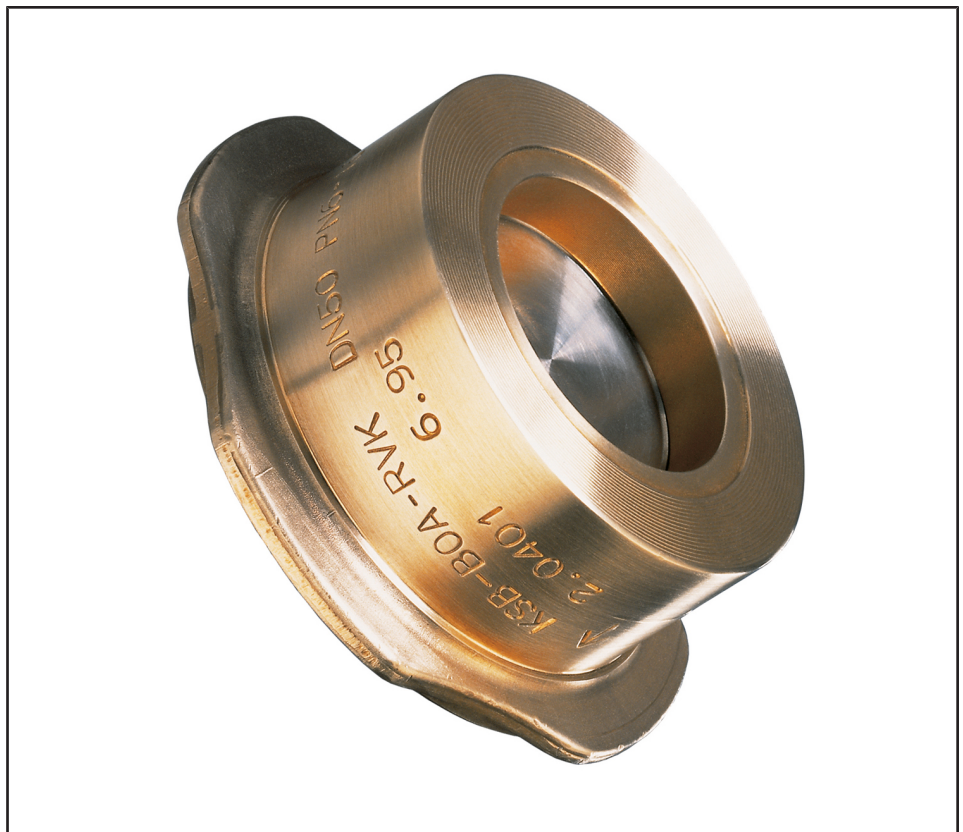

## **Legal information/Copyright**

Type Series Booklet BOA-RVK

All rights reserved. The contents provided herein must neither be distributed, copied, reproduced, edited or processed for any other purpose, nor otherwise transmitted, published or made available to a third party without the manufacturer's express written consent.

Subject to technical modification without prior notice.

© KSB SE & Co. KGaA, Frankenthal 09/08/2019

---

## Contents

<b>Check Valves and Strainers .....</b>	<b>4</b>
Lift Check Valves to DIN/EN .....	4
BOA-RVK .....	4
Main applications .....	4
Fluids handled .....	4
Operating data .....	4
Valve body materials .....	4
Design details .....	4
Product benefits .....	4
Product information .....	4
Related documents .....	5
Purchase order specifications .....	5
Pressure/temperature ratings .....	5
Materials .....	6
Flow characteristics .....	7
Dimensions and weights .....	8
Installation information .....	9

## Check Valves and Strainers

### Lift Check Valves to DIN/EN

## BOA-RVK



#### Main applications

- Hot-water heating systems
- Air-conditioning systems
- Chemical industry
- Process engineering
- Heat recovery systems

#### Fluids handled

- Hot water
- High-temperature hot water
- Other fluids on request.

#### Operating data

Operating properties

Characteristic	Value	
	PN 6 <sup>1)</sup>	PN 6/10/16 <sup>2)</sup>
Nominal pressure	PN 6	PN 6/10/16
Nominal size	DN 15 - 200	DN 15 - 200
Max. permissible pressure [bar]	6	16
Min. permissible temperature [°C]	≥ -20	≥ -20
Max. permissible temperature [°C]	≤ +100	≤ +250

Selection as per pressure/temperature ratings (⇒ Page 5)

- 1) Obturator: metal/plastic plate
- 2) Seat/disc interface: metal
- 3) 100 °C for model with plate/valve disc made of plastic
- 4) Seat/disc interface: metal
- 5) Seat/disc interface: metal/EN-GJL-250 with O-ring

#### Valve body materials

Overview of materials available for DN 15-100, PN 6

Material	Material number	Temperature limit
CuZn40Pb2	2.0402	≤ 100 °C <sup>3)</sup>

Overview of materials available for DN 15-100, PN 6/10/16

Material	Material number	Temperature limit
CuZn40Pb2	2.0402	≤ 250 °C <sup>4)</sup>

Overview of materials available for DN 125-200, PN 6

Material	Material number	Temperature limit
EN-GJL-250	5.1301	≤ 100 °C <sup>5)</sup>

Overview of materials available for DN 125-200, PN 6/10/16

Material	Material number	Temperature limit
EN-GJL-250	5.1301	≤ 250 °C <sup>4)</sup>

#### Design details

##### Design

- Wafer-type lift check valve
- Shut-off by spring-loaded plate or valve disc guided by guide pins
- Centring aid is part of the valve body
- Short face-to-face length to EN 558/49
- External coating:  
DN 15 - 100: body made of brass, without coating  
DN 125 - 200: body made of grey cast iron, coated blue (RAL 5002)

##### Product benefits

- Highly reliable function as plate is accurately guided by three guide pins (up to DN 100).
- Integrally cast centring aid for easy installation.
- Low maintenance requirements due to corrosion-proof body made of brass (DN 15-100) and spring made of stainless steel (all nominal sizes).
- Universal use: Valve can be installed between flanges to DIN EN 1092-1 PN 6-16, DIN EN 1092-2 PN 6-16, ANSI B 16.1 25/125, BS 4504 PN 16 and in any installation position.
- Cost-effective transport and handling due to short face-to-face length and low weight
- Minimum pressure loss by hydraulically favourable flow passage

##### Product information

#### Product information as per Regulation No. 1907/2006 (REACH)

For information as per chemicals Regulation (EC) No. 1907/2006 (REACH), see <http://www.ksb.com/reach>.

## Related documents

### Information/documents

Document	Reference number
BOA-R type series booklet (lift check valves for pressure vessel equipment to German steam boiler regulations TRD 108/TRD 110)	7117.1
BOA-C, -CS, -EKB, -W, -H, -R, -RVK, -S operating manual	0570.8
Typical tender for BOA-RVK PN 6	7119.521
Typical tender for BOA-RVK PN 16	7119.522

### Purchase order specifications

Please specify the following information in all enquiries or purchase orders:

1. Type
2. Nominal pressure
3. Nominal size
4. Reference number

### Pressure/temperature ratings

#### Test pressure and operating pressure

PN	DN	Shell test	Leak test (seat)	Permissible operating pressure [bar] <sup>6)7)</sup>						
		With water		[°C]						
		Tests P10 and P11 to DIN EN 12266-1	Test P12, leakage rate B to DIN EN 12266-1	-20 <sup>8)</sup>	50	80	100	120	200	250
		[bar]	[bar]							
6	15-100	9	6,6	6	6	4	2	-	-	-
6	125-200	9	6,6	-	6	6	6	-	-	-
6/10/16	15-100	24	17,6	16	16	16	16	16	14	13
6/10/16	125-200	24	17,6	-	16	16	16	16	12,8	11,2

6) Intermediate temperatures can be derived by linear interpolation.  
7) Static load  
8) EN-GJL-250 (5.1301) for temperatures down to -10 °C only

Materials

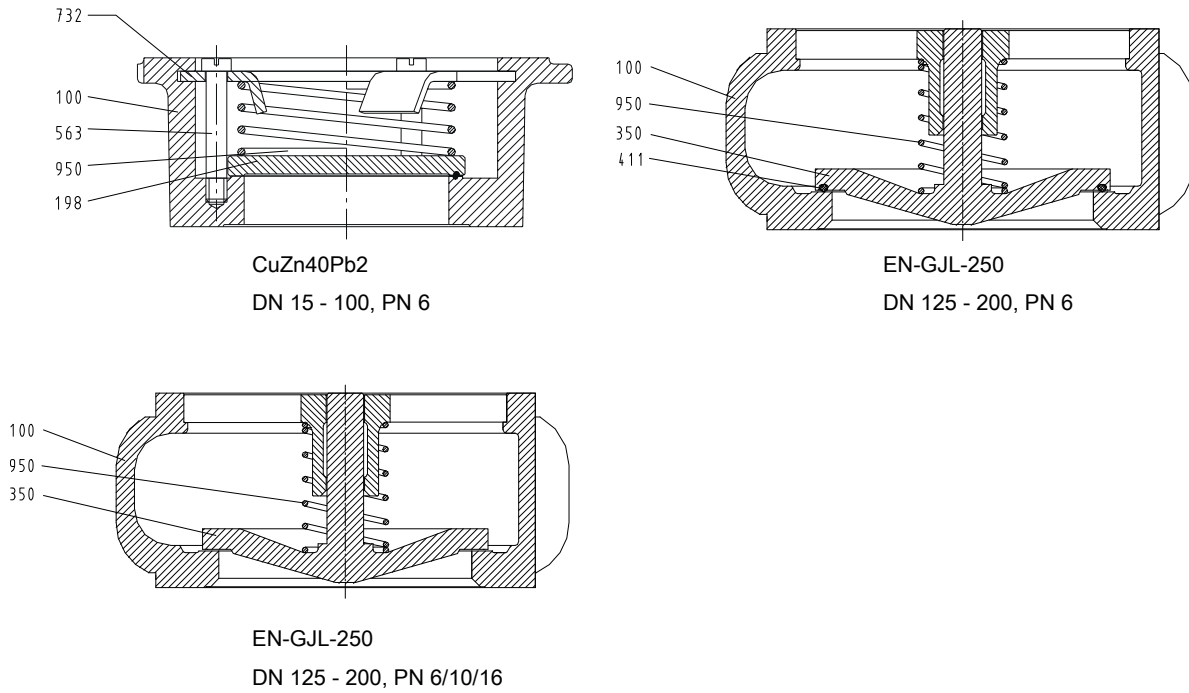
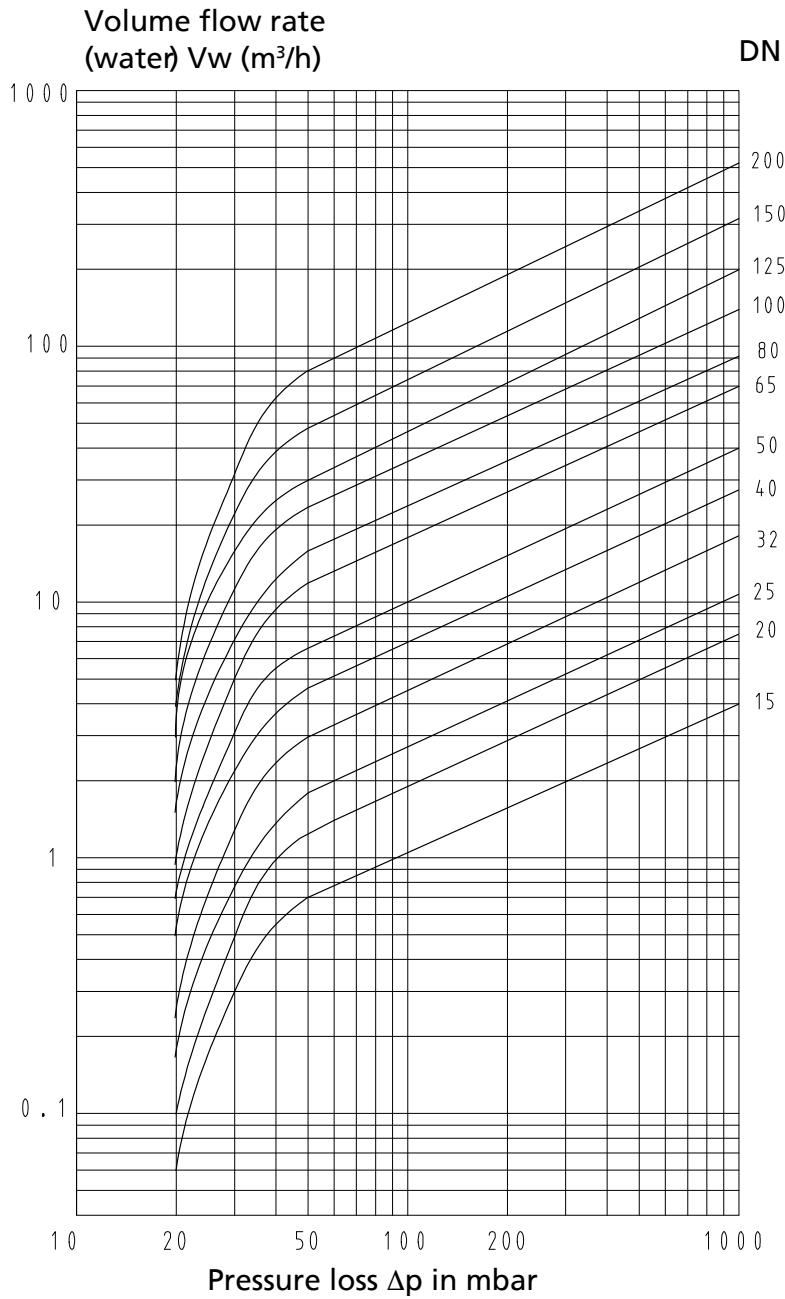

Fig. 1: Sectional drawings

Parts list of DN 15 - 100 PN 6/10/16

Part No.	Description	PN	DN	Material	Note
100	Body	6/10/16	15 - 100	CuZn40Pb2	2.0402
		6/10/16	125 - 200	EN-GJL-250	5.1301
198	Plate	6	15 - 100	PPO-GFK plastics	-
		6/10/16	15 - 100	Stainless steel	1.4301
350	Valve disc	6	125 - 200	EN-GJL-250 with O-ring	5.1301
		6/10/16	125 - 200	EN-GJL-250	5.1301
411	Joint ring	6	125 - 200	EPDM	-
563	Guide pin	-	15 - 100	A2	-
732	Holder	-	15 - 100	Stainless steel	1.4301
950	Spring	-	15 - 200	Stainless steel	1.4571

Flow characteristics



The values indicated in the diagram are valid for water at 20 °C. They have been measured on valves installed in horizontal pipes. In vertical pipes negligible deviations occur when the valves are partially open.

To read the pressure drop for other fluids, the equivalent water volume flow rate must first be calculated using the following formula:

$$\dot{V}_w = \dot{V} \cdot \sqrt{\frac{\rho}{1000}}$$

Symbol	Name
$\dot{V}_w$	Equivalent water volume flow rate [ $m^3/h$ ]
$\rho$	Density of fluid handled (during valve duty) [ $kg/m^3$ ]
$\dot{V}$	Volume flow rate of fluid handled (during valve duty) [ $m^3/h$ ]

Dimensions and weights

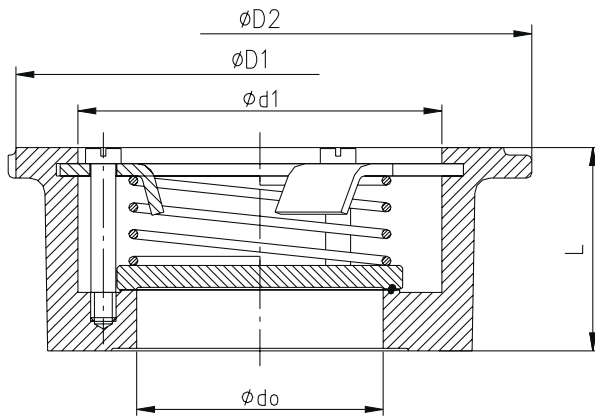

CuZn40Pb2  
DN 15-100

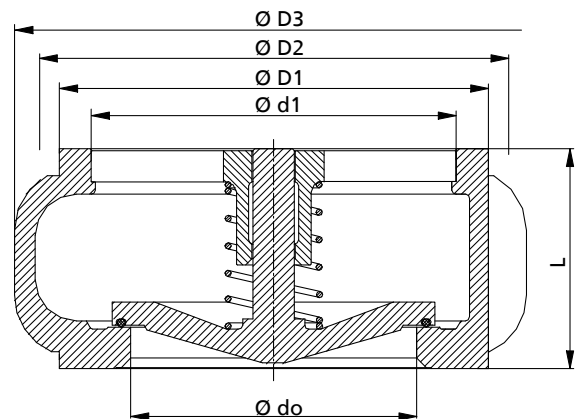

EN-GJL-250  
DN 125-200

Dimensions and weights

PN	DN	L	$\phi D_1^{9)}$	$\phi D_2^{10)}$	$\phi D_3$	$\phi do$	$\phi d_1$	[kg]
		[mm]	[mm]	[mm]	[mm]	[mm]	[mm]	
6/10/16	15	16	43	51	-	15	28	0,2
	20	19	53	61	-	20	33	0,3
	25	22	64	71	-	25	41,5	0,3
	32	28	76	82	-	32	51,5	0,5
	40	31,5	86	92	-	40	58,5	0,7
	50	40	96	108	-	48,5	71,5	0,9
	65	46	116	127	-	63	90	1,2
	80	50	132	142	-	77	100	2
	100	60	152	162	-	96	126	2,8
	125	90	184	192	210	118	148	10
	150	106	209	218	250	138	176	13
	200	140	263	273	273	188	230	22

Mating dimensions as per standard

Face-to-face lengths: EN 558/49  
DIN EN 1092-1 PN 6-16

Can be installed between  
flanges to: DIN EN 1092-2 PN 6-16  
ANSI B 16.1 25/125  
BS 4504 PN 6-16

9) Centring diameter for PN 6  
10) Centring diameter for PN 16



### Installation information

**i** The flow direction must correspond to the flow direction arrow.

**i** A minimum pressure is required for opening. If this minimum pressure is not reached, the closing spring can be dismantled. Valves without closing spring shall only be installed in vertical pipes with upward flow.

Opening pressures ( $p_o$ ) as a function of flow direction [mbar]

DN	↔	↓	↑	↑ Without spring
15	20	16	24	4
20	20	16	24	4
25	20	16	24	4
32	20	16	24	4
40	20	15,5	24,5	4,5
50	20	15	25	5
65	20	14,5	25,5	5,5
80	20	13,5	26,5	6,5
100	20	13,5	26,5	6,5
125	20	-	32	12
150	20	-	34	14
200	20	-	35	15







**KSB SE & Co. KGaA**  
Johann-Klein-Straße 9 • 67227 Frankenthal (Germany)  
Tel. +49 6233 86-0  
[www.ksb.com](http://www.ksb.com)